

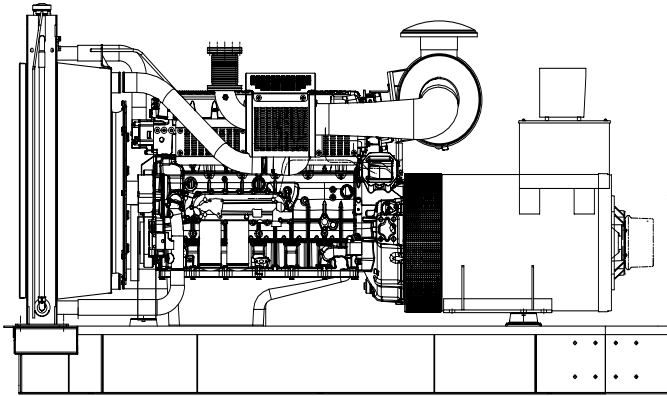

Partech Industries, Inc

Model: PTA-360-IV Diesel Generator Set



FEATURES

- Partech Industries provides one-source responsibility for the generator system and its accessories.
- All units and components are factory tested during prototype and manufacturing stages assuring long product life.
- Generator set accepts one-step 100% of full load per NFPA 110.
- A **one-year** limited **warranty** covers all systems and components. Extended warranties are available.
- Rugged 4 cycle heavy-duty diesel engine, with direct fuel injection system and swirl intake ports combine for a low fuel consumption and excellent transient response.
- **Generator features:**
 - Unique Volts per Hertz compensated electronic AVR excitation system delivers reliable voltage response for in rush loads.
 - Brushless, rotating-field generator has low reactance, 2/3 pitch, class H insulation, minimizes voltage distortion when powering non-linear loads.
- **More features:**
 - Controllers are available to meet your most demanding applications.
 - In the event of low oil pressure or high coolant temperature the self-protecting system will automatically stop the engine.

GENERATOR SET RATINGS

Model	Volt Code	Voltage	Winding Connection	Phase	Power Factor	Hz	Amps Standby	Standby kW/kVA	Prime kW/kVA
PTA360IV	61	480/277	12 - HI WYE	3	0.8	60	527	358/448	323/404
PTA360IV	63	440/254	12 - HI WYE	3	0.8	60	581	358/448	323/404
PTA360IV	64	240/139	12 - HI DELTA	3	0.8	60	1053	358/448	323/404
PTA360IV	65	220/127	12 - LOW WYE	3	0.8	60	1155	358/448	323/404
PTA360IV	66	208/120	12 - LOW WYE	3	0.8	60	1220	358/448	323/404
PTA360IV	67	240/120	12 - 2 DELTA	1	1.0	60	1458	358/358	323/404
PTA360IV	51	415/240	12 - HI WYE	3	0.8	50	582	321/401	288/360
PTA360IV	53	380/220	12 - HI WYE	3	0.8	50	624	321/401	288/360
PTA360IV	55	220/127	12 - LOW WYE	3	0.8	50	1079	321/401	288/360
PTA360IV	57	220/110	12 - 2 DELTA	1	1.0	50	1459	321/401	288/360

Stand-By ratings are continuous electrical service during the interruption of normal power. No overload capacity is specified at these ratings. Prime ratings available with variable loads are continuous, 10% overload capacity for one hour in twelve hours periods. Both ratings per BS 5514, DIN 6271, ISO-3046
Many industrial, commercial and residential voltages are available

ALTERNATOR SPECIFICATIONS

Type	Four pole, revolving field
Rotor Insulation	Class H
Temperature Rise	150°C Standby
Material	Epoxy resin
Line-To-Line Harmonic Factor (Max)	5%
Telephone Interference Factor (Tif)	1%
Voltage Regulator	Solid State
Cooling	Self-ventilated and drip proof
Bearing	1 each, pre-lubed
Coupling	Direct, Flexible Disc
Load Capacity (Standby)	100%
Overload Capacity (Prime)	110%
Voltage Regulation	
No Load To Full Load	±1 %
One Step Load Acceptance	
Per NFPA 110	100%

- ❑ Four pole, revolving field, direct coupled to engine flywheel, provides excellent alignment.
- ❑ Insulation is of class H, ready to be used on harsh environments where sea spray, sand and chemical corrosion are existing factors.
- ❑ Voltage regulator provides Volts/Hertz compensation to improve the motor starting capabilities, therefore support the engine handling transient loads.
- ❑ Dynamically balanced rotor, with damper winding, help dissipate transient voltage interference during load variations.
- ❑ The windings have a 2/3 pitch in order to reduce the harmonic content of voltage.
- ❑ Robust mechanical structure permits easy access to connections.

ENGINE SPECIFICATIONS

Manufacturer	IVECO
Model	CURSOR13TE2
Bore	5.31in. (135mm)
Stroke	5.90in. (150mm)
Number Of Cylinders	6
Piston Displacement	787.196 in. ³ (12.9L)
Compression Ratio	16.5:1
Combustion System	Direct Electronic Unity Injector
Engine Type	In-Line – 4 Cycle
Aspiration	Turbocharged Aftercooled
Engine Crankcase Vent System	Open
Cylinder	Replaceable Wet Liners
Crankshaft Material	Forged Steel
Governor, Make	Isocronous
Frequency Regulation,	
No Load To Full Load	.5 %
Air Cleaner	Dry Element
Flywheel housing / Flywheel	SAE1 / 14”

- ❑ Robust industrial grade IVECO diesel engine, for reliable endurance.
- ❑ Direct fuel injection system and swirl intake ports combine for a low fuel consumption and excellent transient response.
- ❑ Cylinder Head provides superior airflow through specially designed intake manifold ports, large valves and seats resulting in superior engine performance in torque reserve, fuel consumption and emissions.
- ❑ Replaceable Wet-Type Cylinder Liners, provide excellent heat dissipation. Precision machined for long life.
- ❑ Dynamically Balanced Crankshaft, with induction-hardened journal surfaces significantly increases wear life.
- ❑ Multi V Belt Fan Drive provides superior noise and vibration reduction.

STANDARD EQUIPMENT

ENGINE

- Air Cleaner
- Fuel Pump
- Fuel Filter
- Oil Pump
- Full Flow Oil Filter
- Jacket Water Pump
- Thermostat and Housing
- Exhaust Manifold Dry
- Oil Cooler
- Blower Fan & Fan Drive
- Radiator - Unit Mounted
- Electric Starting Motor 12v

- Turbocharged
- Housing & Flywheel
- Charging Alternator - 12v
- Battery Kit & Battery Rack

GENERATOR

- Synchronous, Brush-less
- Four Pole
- Single Bearing
- Direct Coupled With Flex
- Class H Insulation
- Drip-Proof Construction

CONTROL PANEL

- Deep Sea Model 5120,

- Automatic Mains Failure module provides engine and electrical metering facilities via the LCD display, accessed via the SRCOLL pushbutton
- Ac Voltmeter
- Ac Ammeter
- Frequency Meter
- Vibration Shock Mounts
- Engine Shutdowns
- * High Water Temperature
- * Low Oil Pressure

- * Battery Voltmeter
- * Water Temperature
- * Oil Pressure
- * Running Time Meter
- LED and LCD alarm indication

GENERAL

- Integrated Fuel Tank
- Industrial Muffler
- Rain Cap
- Lifting Points
- Acrylic Enamel Paint

INSTALLATION AND APPLICATION DATA

	Item	Units	Type of Operation and Application			
			60 Hz		50 Hz	
			Prime	Standby	Prime	Standby
Engine	Rated Speed	rpm	1800		1500	
	Gross Engine Output	bhp (kWm)	432 (323)	479 (358)	385 (288)	430 (321)
	BMEP	psi (kPa)	242 (1669)	268 (1850)	259 (17.86)	289 (1990)
	Mean Piston Speed	Ft/s (m/s)	29.5 (9)		24.6 (7.5)	
Cooling System	Ambient Air Temperature	°F (°C)	122 (50)			
	Coolant Capacity engine only	Gal (l)	~ 5.2 (19.5)			
	Coolant Capacity engine + radiator	Gal (l)	~ 17.7 (67)			
	Cooling system		Liquid (water + 50% Paraflu 11)			
	Pusher Fan Air Flow	ft ³ /s (m ³ /s)	217.9 (6.17)		181.5 (5.14)	
	Heat rejection to coolant	kcal/kWh	348		325	
	Heat rejection to air (intercooler)	kcal/kWh	140		132	
Fuel System	Fuel Type		Diesel N°2			
	Fuel Consumption @ 50% Power	l/h (g/kWh)	42.8 (188.1)	35.6 (188.2)	37.7 (174.2)	35.2 (173.7)
	Fuel Consumption @ 80% Power	l/h (g/kWh)	66.1 (181.7)	54.9 (180.7)	57.4 (165.7)	53.6 (165.7)
	Fuel Consumption @ 100% Power	l/h (g/kWh)	82.6 (181.8)	68.7 (181.7)	73.2 (169.2)	68.2 (168.8)
Air Requirement	Intake Air Flow	Ft ³ /min (m ³ /min)	575.6 (16.3)		498 (14.1)	
	Air Flow Restriction-Clean AirFilter	In.H ₂ O (kPa)	8.02 (2)			
	Air Flow Restriction-Dirty Air Filter	In.H ₂ O (kPa)	20.07 (5)			
Exhaust System	Exhaust Gas Flow	lb/m (Kg/h)	45.12 (1228)		39.2 (1067)	
	Exhaust Temperature	°F (°C)	1063.4 (573)		1083.2 (584)	
	Maximun Allowable Back Pressure	In.H ₂ O (kPa)	20.07 (5)			
	Connection Outlet Size Diameter	In. (mm)	6 (152.4)			
Lubrication System	Total Engine Oil Cap. w/ Filter(s)	Gal (l)	9.3 (35)			
	Oil Filter Type		Cartridge			
	Oil Cooler		Water Cooled			
	Lube oil specifications grade		SAE 15W – 40			
	Lube oil consumption		< 0.1% of fuel consumption			
	Oil and filters interval for replacement	hours	1200 (0°F / -18°C)			
Engine Electricals	Battery Charging Alternator	Volts, Ground	24VCC, Negative			
	Battery Charging Alternator	Rated amps	45			
	Starter Motor	Volts, Ground	24VCC, Negative			
	Recommended Battery Cold Crank	CCA amps	650 / -0 °F (-18 °C)			
Ambient Deration	Altitude Deration 3% per 1000ft (300m) above	Ft (m)	6561.7 (2000)			
	Temperature Deration 3% per 10°F (5.5°C) above	°F (°C)	104 (40)			

OPTIONAL EQUIPMENT

Cooling System

- Remote Radiator
- Jacket Water Heater
- Crankcase Oil Heater

Fuel System

- Fuel/Water Separator
- Day Tank
- Above Ground Fuel Tank
- Auxiliary Fuel Pump
- Sub-Base Fuel Tank
 - Double Wall
 - UL Listed

Exhaust System

- Industrial Grade Muffler
- Residential Grade Muffler
- Critical Grade Muffler
- Super Critical Grade Muffler

Start System

- Battery Nicad

- Battery Warmer Plate
- Battery Charger
 - Automatic Float Equalizing
 - Trickle

Switchgear

- Main Line Circuit Breaker
 - Shunt trip
 - Auxiliary switch
- Automatic Transfer Switch
- Paralleling
- Protective Relays

Generator

- Permanent Magnet Excitation
- Space Heaters
- Temperature Rise Detectors

Control Panel

- Emergency stop button
- Microprocessor Control Panel
- NFPA 110 Ready

- Remote Annunciation Panel
- Audible Alarm

General

- Spring vibration isolators
- Automatic Transfer Switch
- Metal Enclosure
 - Weather Resistant
 - Sound Attenuated
 - Aluminum
- Interior lights AC or DC
- Trailer
- Export Packaging
- Special Testing
- Warranties
 - ____ Year

For Other Options Consult

DIMENSIONS AND WEIGHT

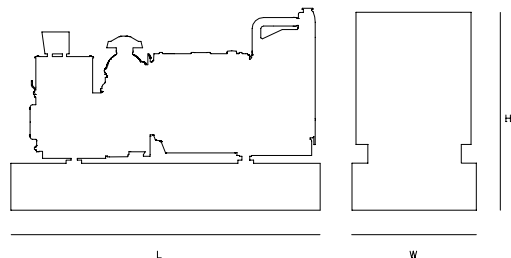

	Units	Open Unit	Enclosed Unit	Sound Att. Unit
Length	In. (mm)	128 (3251)	128 (3251)	171.5 (4356)
Width	In. (mm)	56 (1422)	56 (1422)	56 (1422)
Height	In. (mm)	69 (1753)	83 (2108)	83 (2108)
Weight	Lbs (kg)	6199 (2812)	6499 (2948)	6635 (3010)

General configuration for reference only, do not use these dimensions for installation purposes. Contact your local dealer for certified drawings.



All Specifications and Materials are subject to change without prior notice.

Partech Industries, Inc.

5773 NW 151st Street,
Miami Lakes, FL 33014 USA

Tel 305-751-0160 Fax 305-757-9809
e-mail: sales @ partech.us

www.partech.us

