

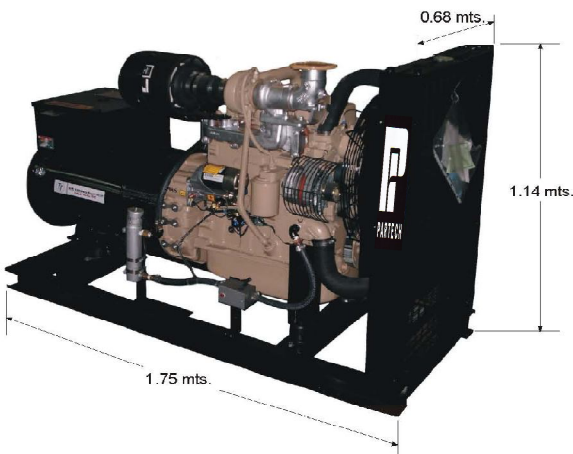

Rating:	60 kW Standby at 60 Hz
Make:	Cummins
Type:	4 Cycle.
Engine Model:	4BT3.9G4
Gross Engine Power Output:	102 BHP a 1800 rpm.
Cylinder:	4 in Line
Bore X Stroke:	102 x 120 mm.
Displacement:	3.92 Lts.
Piston Speed:	7.2 m / Seg.
Compression Ratio:	16.5 : 1
Fuel Consumption:	19.0 Lts./Hrs.
Aspiration:	Turbocharged
Electrical System:	12 volts.
Oil Total System Capacity:	10.9 Lts.
Electric Governor:	Mechanic (Option = Electronic)
Water Preheater:	400 Watts in Monoblock



PTOM60C



Weight: (kgs) : 730 kgs
Dimensions (cm) : L 175 x W 68 x H 114 cm

Control System: Set Mounted Dale 3100 Autostart Control Panel.

Engine: All heavy Duty, water cooled Diesel Engine, include starter and battery charging alternator; high ambient set mounted radiator cooling system.

Alternator: Brushless design, screen protected, fan ventilated, drip proof in accordance with IP 21. Insulation class H, radio interference suppression, voltage regulation is maintained within +/- 1% from no load to full load at any power factor between 0.8 lagging and unity, inclusive of a speed variation of upto 4%.

Electrical System: 12 Volt system with battery charging alternator.

Documentation: A full set of operation and maintenance manuals.

Factory Test: The generator set is load tested before dispatch.

Authorized Distributor:

Partech Industries, Inc.

5773 NW 151 Street
 Miami Lakes, FL 33014 USA

Tel 305-751-0160
 Fax 305-757-9809
 E-MAIL: sales@partech.us

www.partech.us

